

CETOL 60TM



2011 U2U CONFERENCE
TEXAS MOTOR SPEEDWAY, OCT 25-26



Dimensional Management



Praveen Gomer and Ajay Balachandran

“Poor quality products are cost to society.”

- Genichi Taguchi



A Product is an assembly built out of multiple parts; each designed individually but to perform collectively as an assembly to deliver desired functions.

Engine Timing Schematic

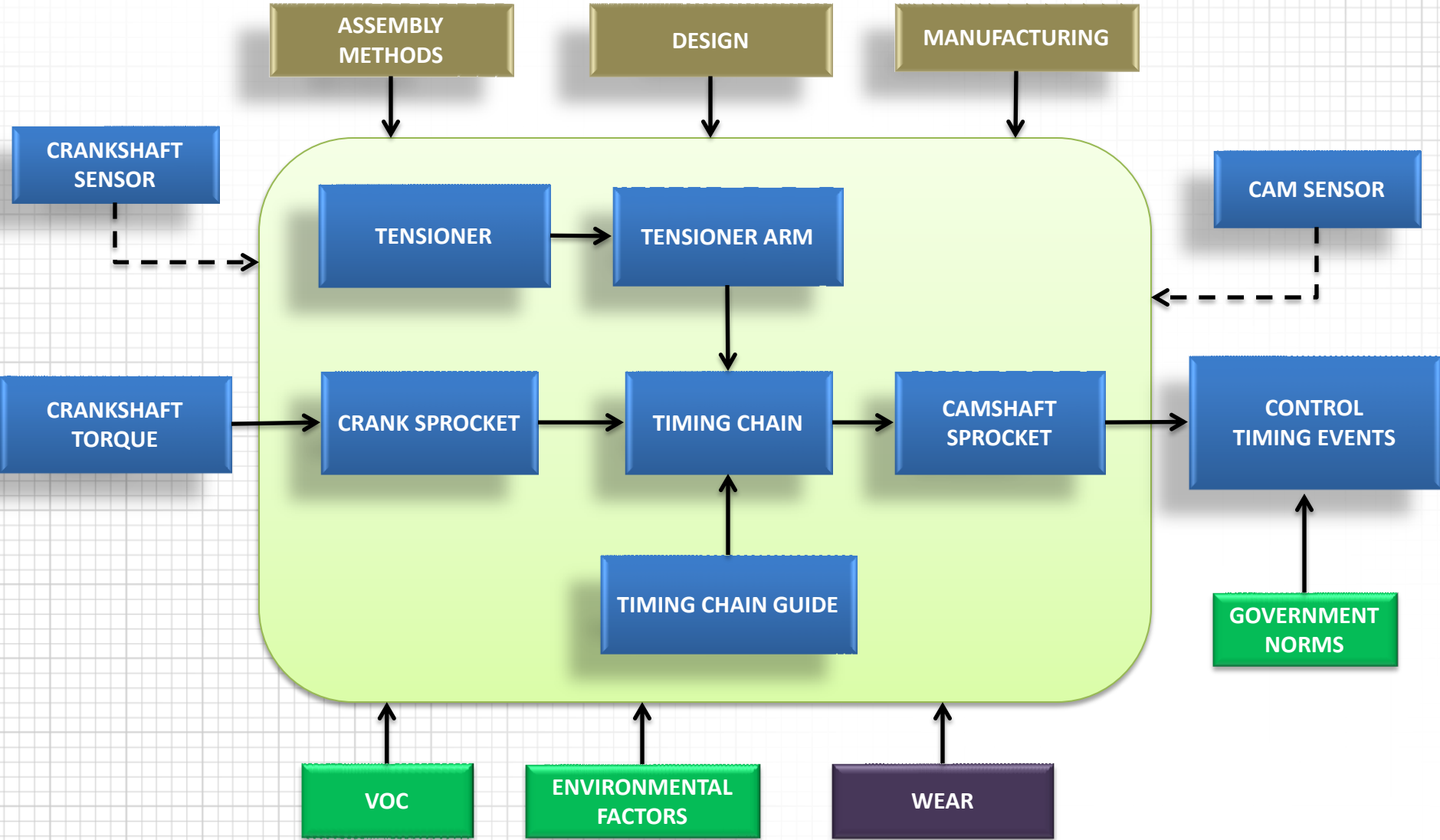

Measureable Parameters

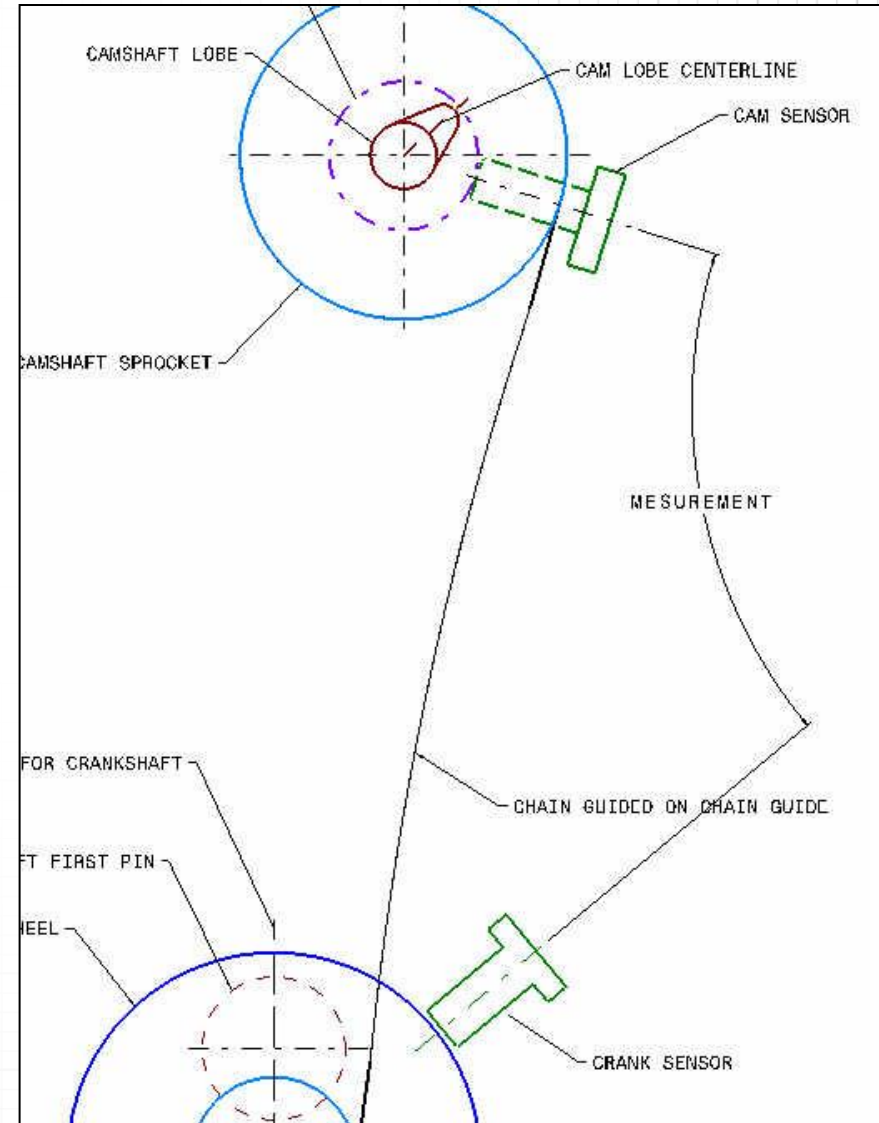
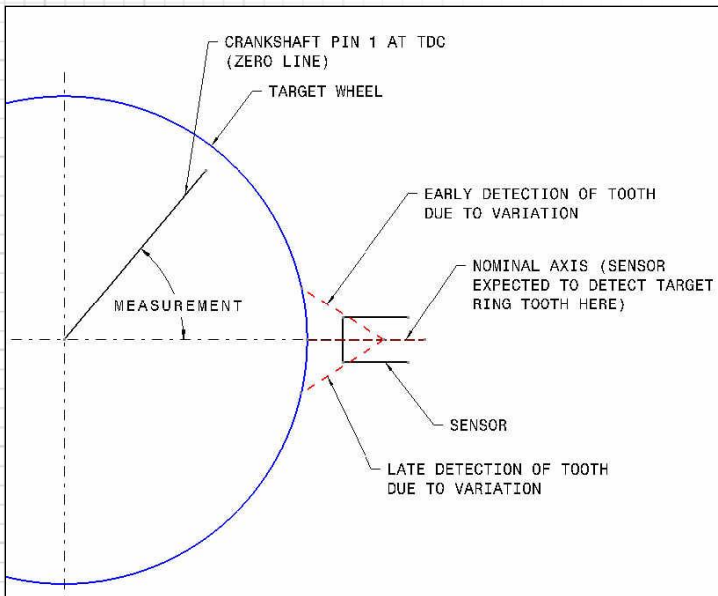
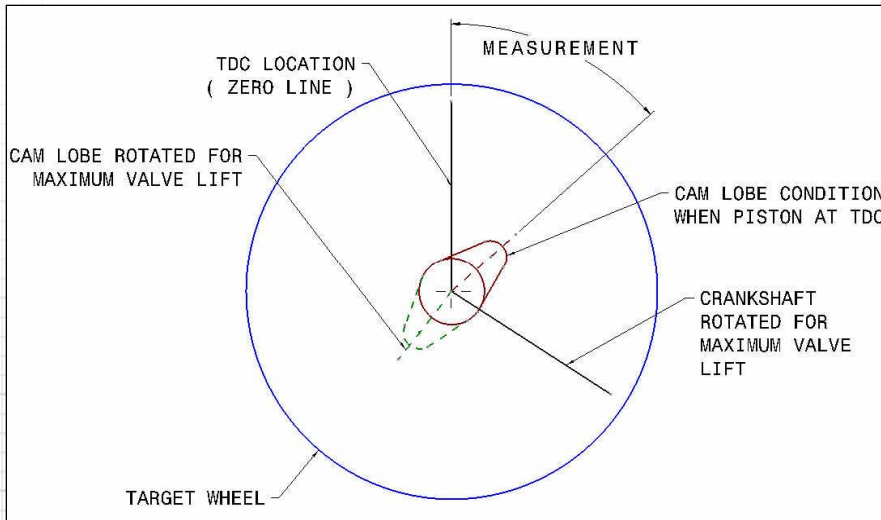

Modeling Challenges

- Building the kinematic model to transfer variations from crankshaft to camshaft.
- Considering chain stretch and wear.
- Consider thermal growth in the system.
- Wrap of Primary and Secondary Chains
- Cam Phasers internal errors
- Simulating impact of assembly variation of position sensors on target ring readings
- Assembly methods adopted in plants resulting in components being biased in a particular direction always.
- System level error calculation utilizing the sensitivity matrix from measurements.

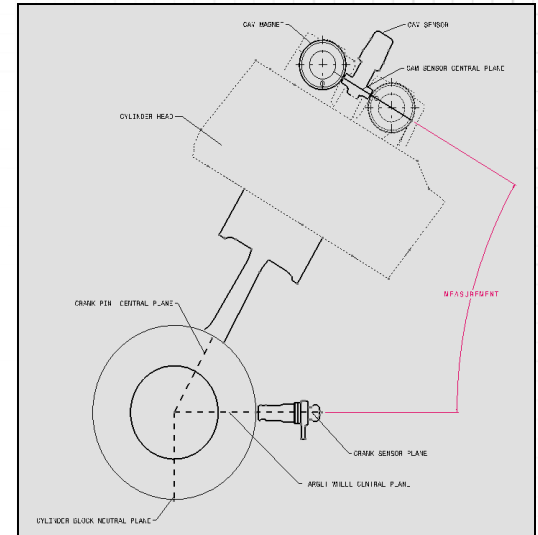

System Variation : Crank - Cam Sensor

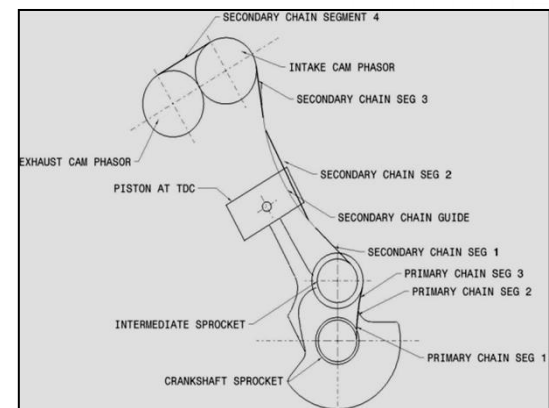

Kinematic Modeling

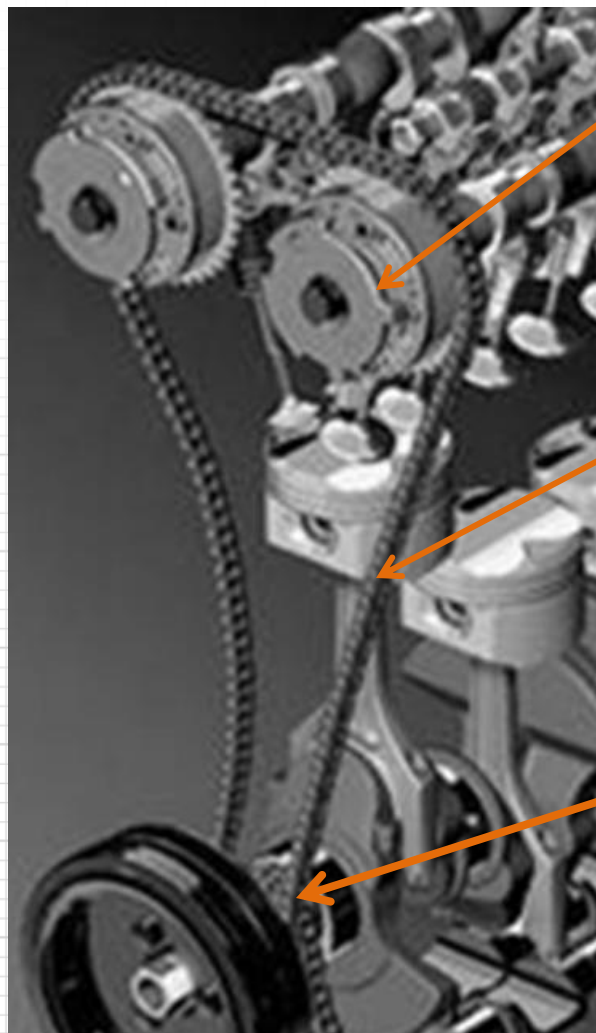

Camshaft Phaser

Chain

Sprocket

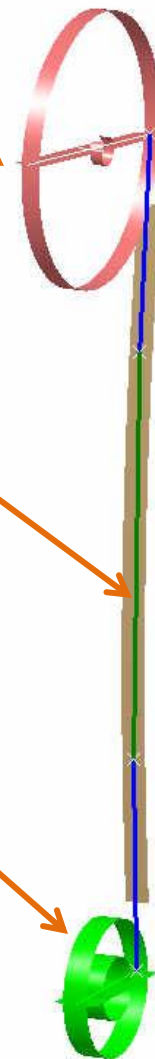

Kinematic Modeling

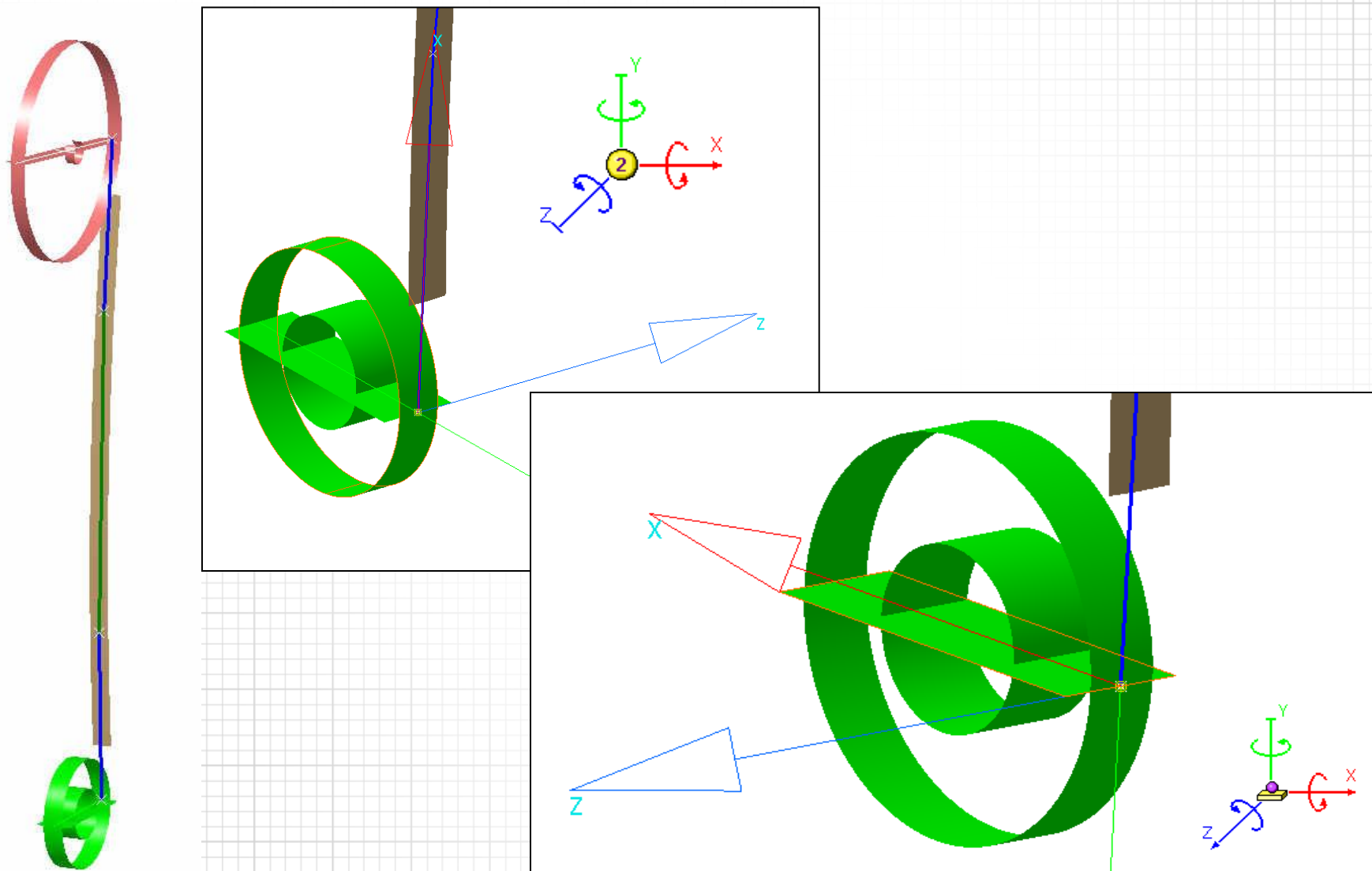

Kinematic Modeling

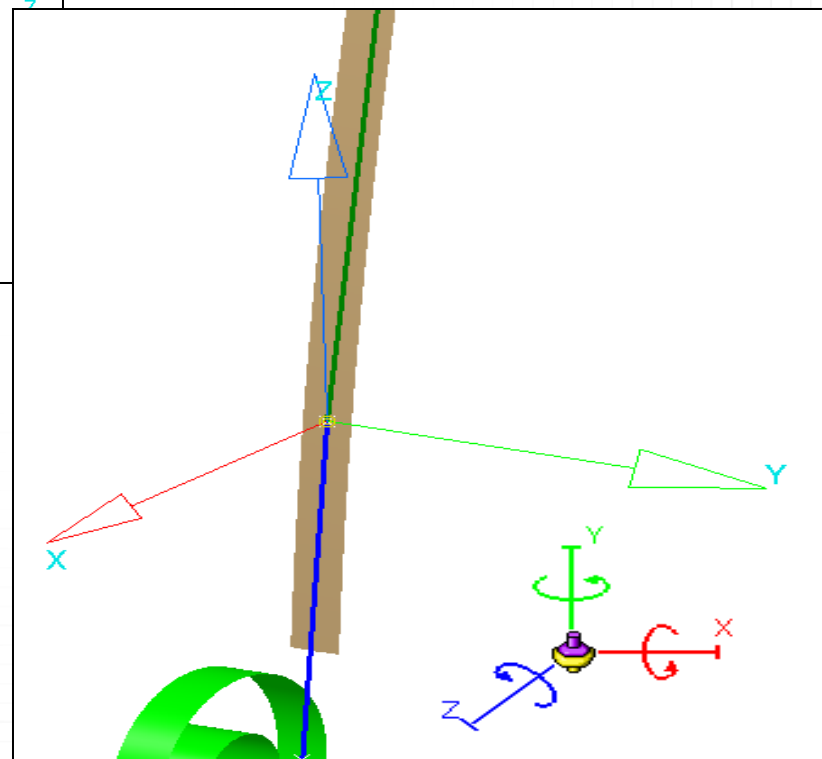
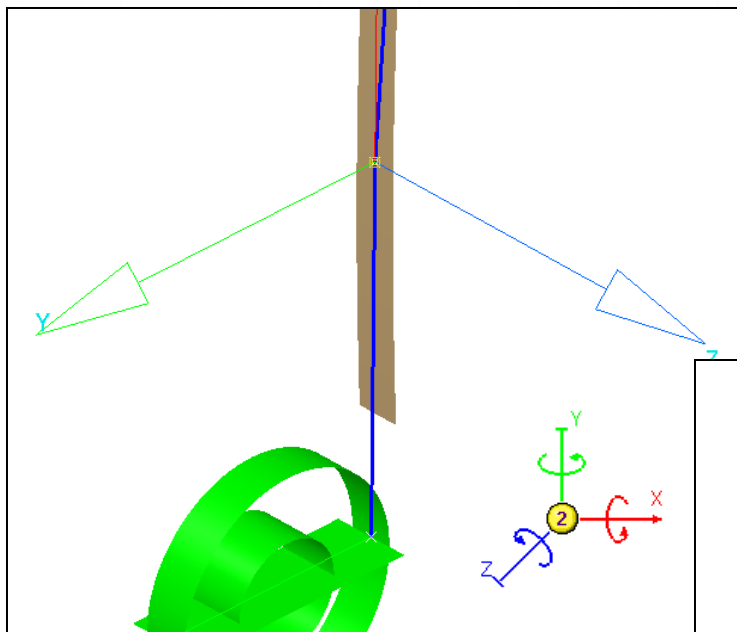
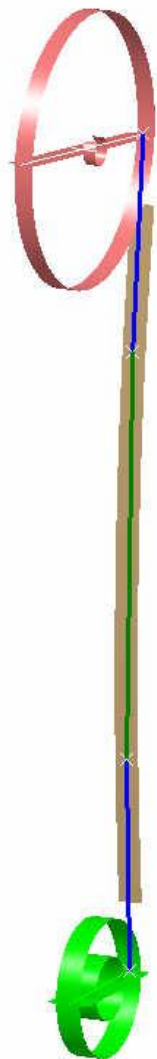

Kinematic Modeling

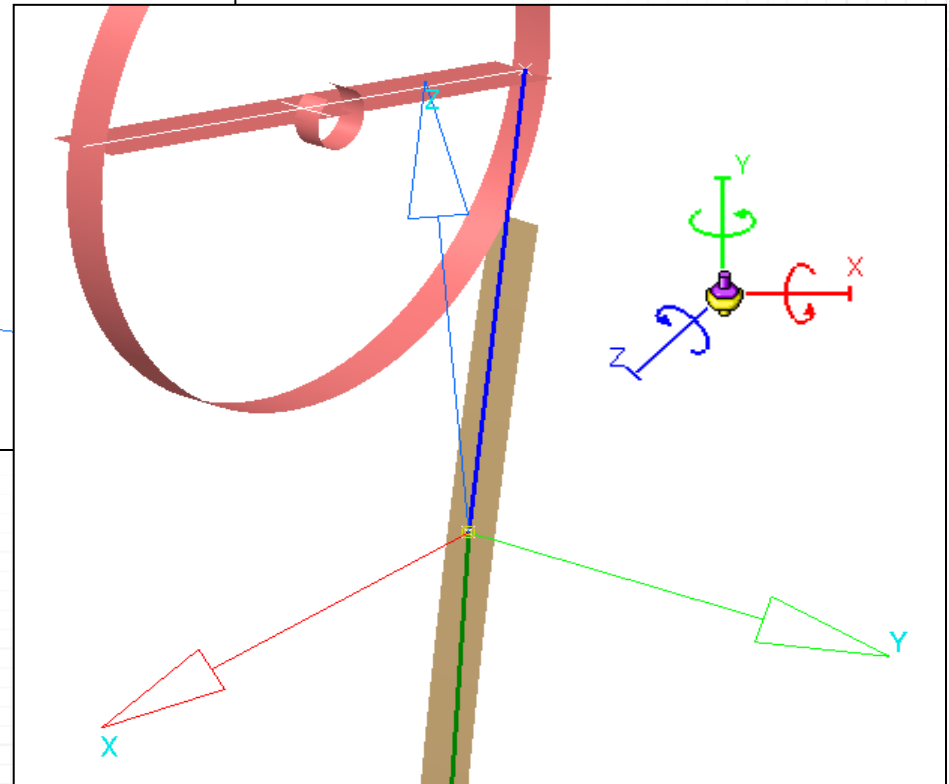
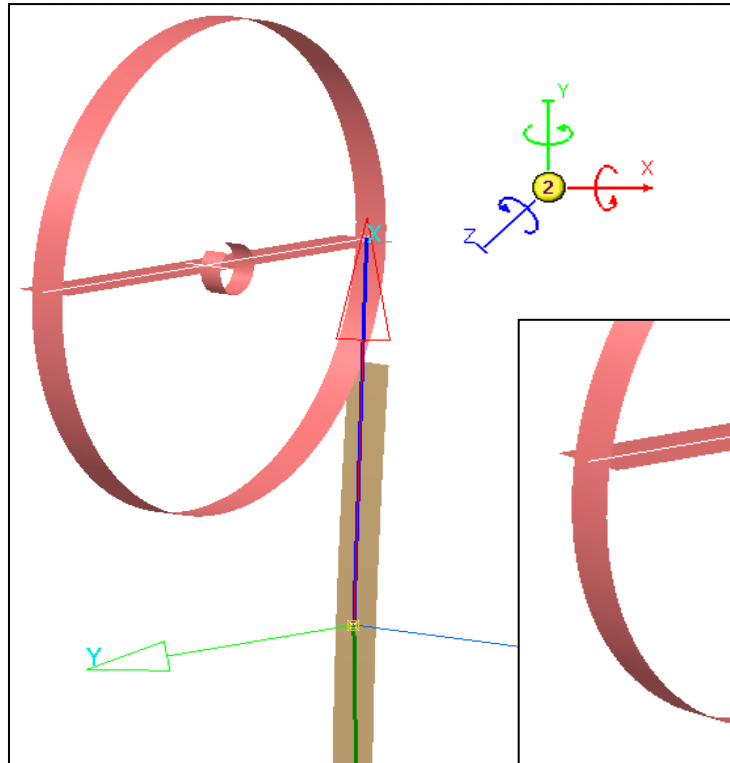
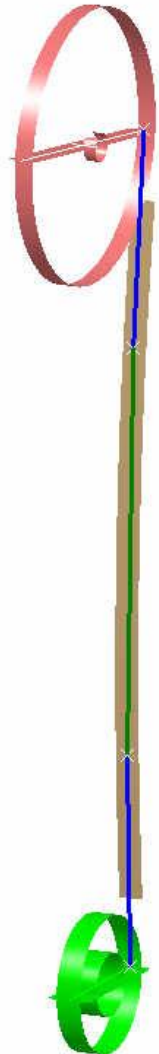

Kinematic Modeling

CETOL6™

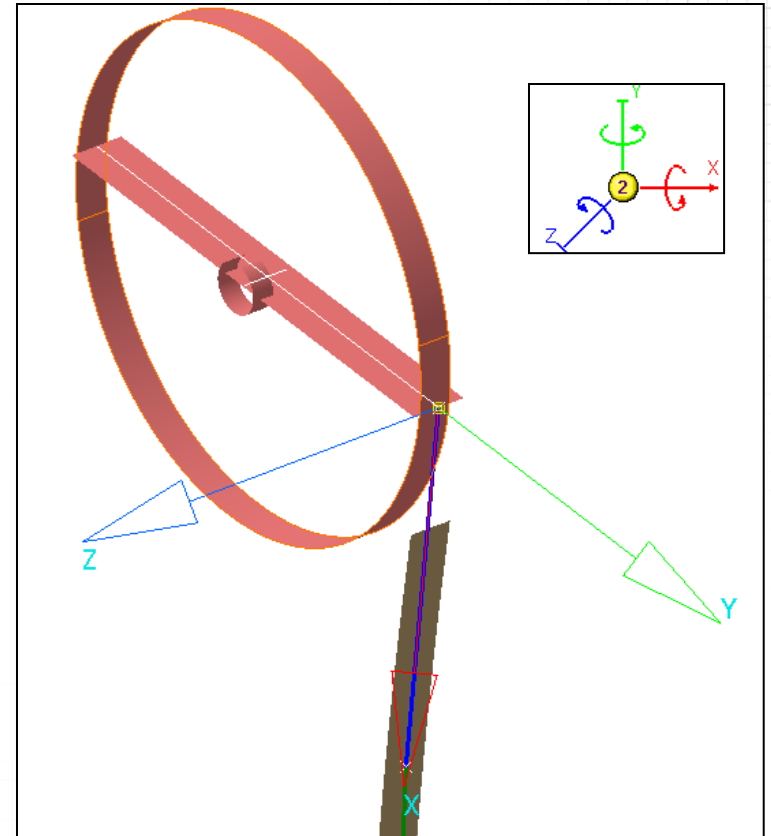
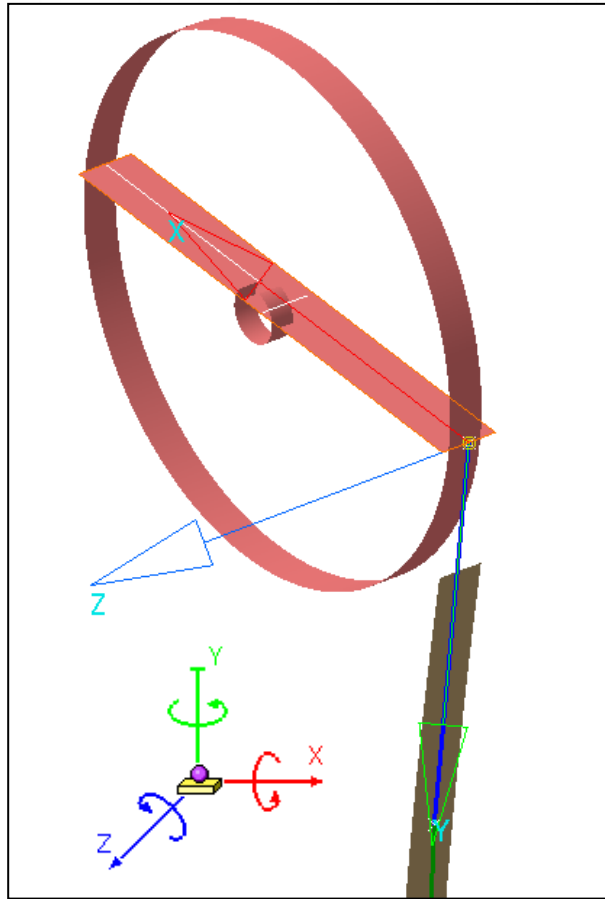
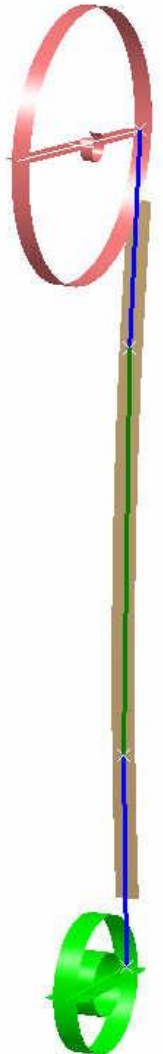

System Level Error Calculation

- System Level Error is a combined effect of Mechanical Errors and Sensor Assembly Error.
- Direct Measurement would not give the desired outcome. Effect of Camshaft, Crankshaft, Chain etc would be ignored.
- Cetol 8.2 builds a separate loop for each measurement objective.
- Number of parameters for each measurement differs
- Order of these parameters is also different for different measurements
- Direct addition of Sensitivity which was possible in CETOL 7.2 is not possible.

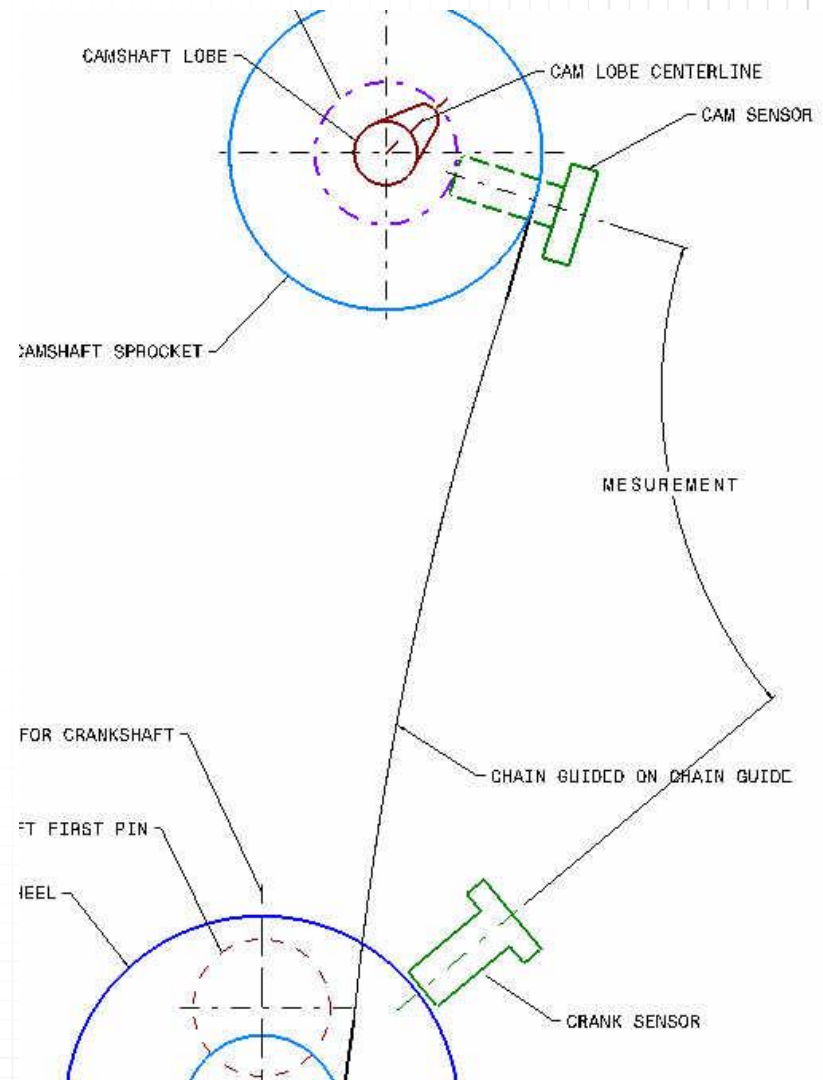

Combined Measurement Tool



```
C:\WINDOWS\system32\cmd.exe
Microsoft Windows [Version 5.2.3790.1]
(C) Copyright 1985-2003 Microsoft Corp.

C:\Documents and Settings\334134>cd desktop
C:\Documents and Settings\334134\Desktop>cd T1
C:\Documents and Settings\334134\Desktop\T1>Cetol_CombinedMeasurement T2.cxm
CXM file has been modified using the following linear combination of measurements:
10_System Level Error_Intake = (2 * 09_Cam Sensor Error Total) + (2 * 01_Error b
etween Intake camlobe C/L and Crankpin Axis) + (1 * 06_Total Crank Sensor Error)

C:\Documents and Settings\334134\Desktop\T1>_
```



$$\text{Total Measure} = (\text{Coeff1} * \text{Measure1}) + (\text{Coeff2} * \text{Measure2}) + \dots + (\text{CoeffN} * \text{MeasureN})$$

Weighted sum of sensitivities of each feature for derived measurement

Percentage In Specification, Standard Deviation and Major Contributors Calculated

Sensitivity Matrix Determination

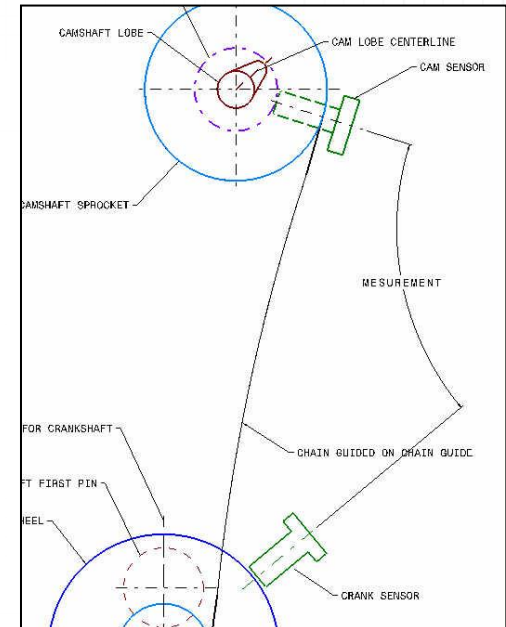
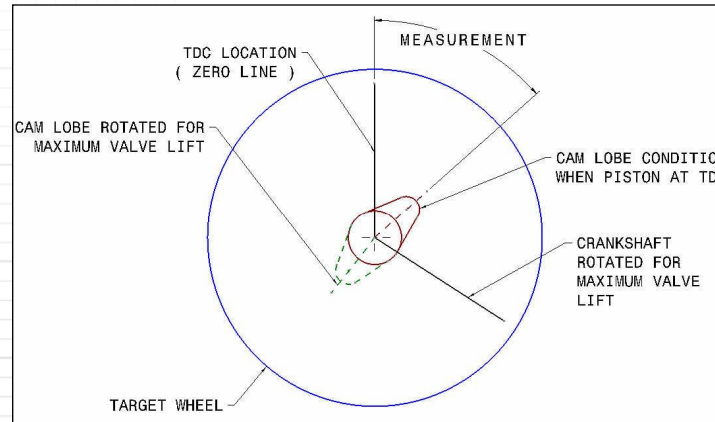
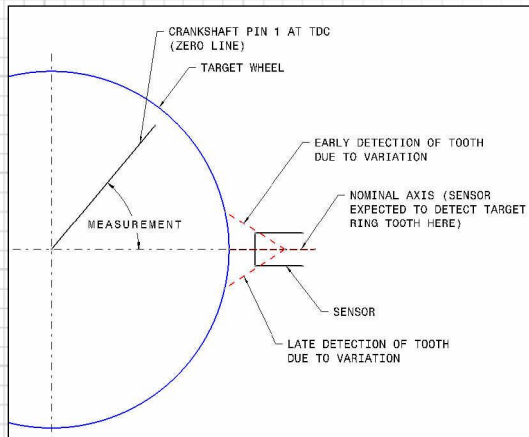
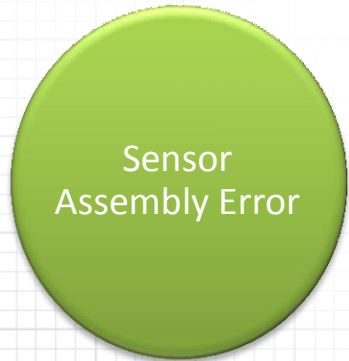

Sensitivity Matrix Determination

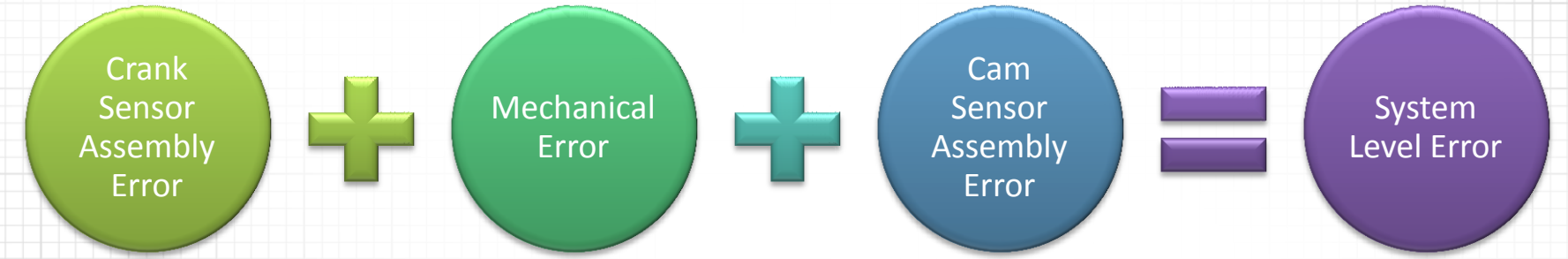

Configuration Joint

Under Constrained Configuration

Measurement Coefficient's

Combined Measurement Tool

Configuration Joint

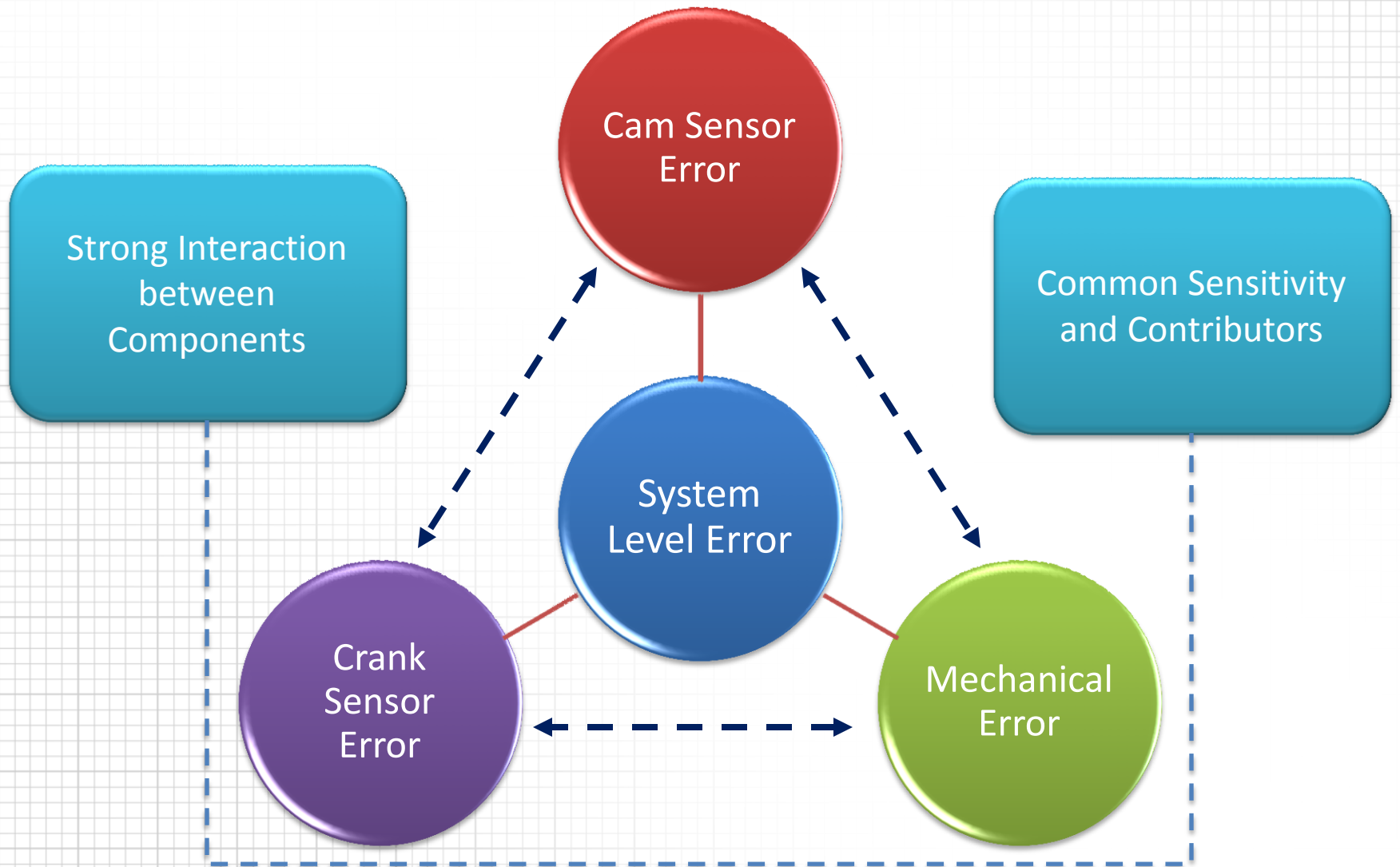

Measurement Coefficient's



Crank Sensor Error

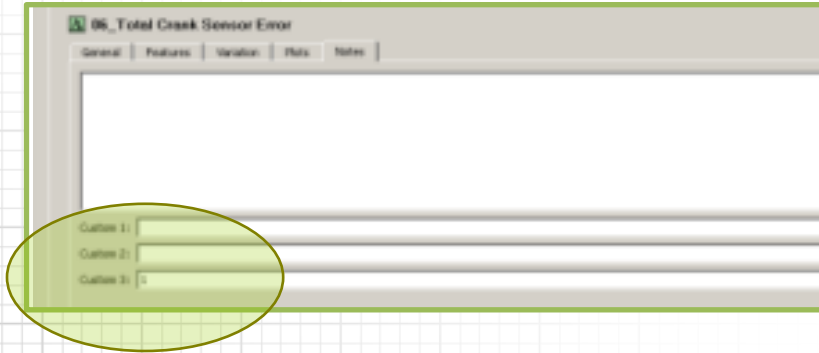

Cam Sensor Error

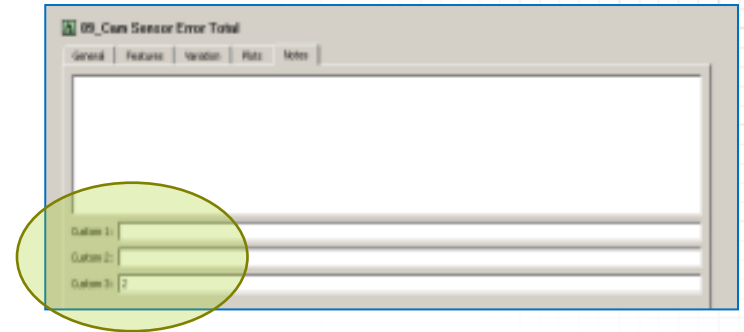

Mechanical Error

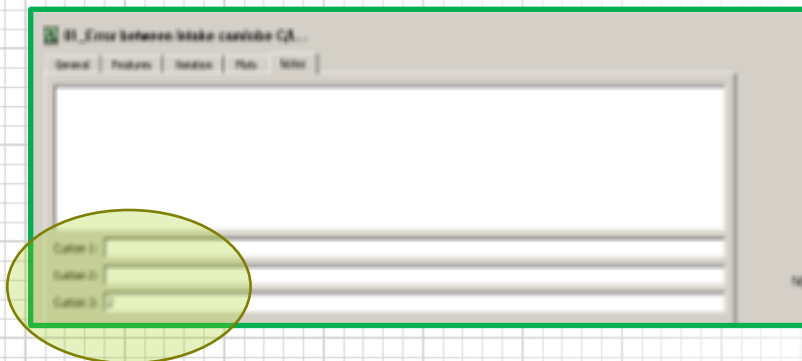

System Level Error



Combined Measurement Tool



Address C:\Documents and Settings\334134\Desktop\T1

Name	Size	Type	Date Modified
T2	1,813 KB	CETOL 6 Sigma v8	8/9/2011 10:21 PM
CETOL_CombinedMeasurement	24 KB	Application	5/10/2011 11:36 AM

```
C:\WINDOWS\system32\cmd.exe
Microsoft Windows [Version 5.2.3798]
(C) Copyright 1985-2003 Microsoft Corp.

C:\Documents and Settings\334134>cd desktop
C:\Documents and Settings\334134\Desktop>cd T1
C:\Documents and Settings\334134\Desktop\T1>Cetol_CombinedMeasurement T2.cxm
CXM file has been modified using the following linear combination of measurement
as:
10_System Level Error Intake = (2 * 09_Can Sensor Error Total) + (2 * 01_Error b
etween Intake camlobe C/L and Crankpin Axis) + (1 * 06_Total Crank Sensor Error)

C:\Documents and Settings\334134\Desktop\T1>_
```

Linear Combination formula appears as per the coefficients in the CXM file

Value Additions

- Effect of Assembly Biasing
- Thermal growth
- Chain elongation and System Wear
- Production data incorporated
- System Optimization.
- Complete system level analysis using mechanical and environmental variables

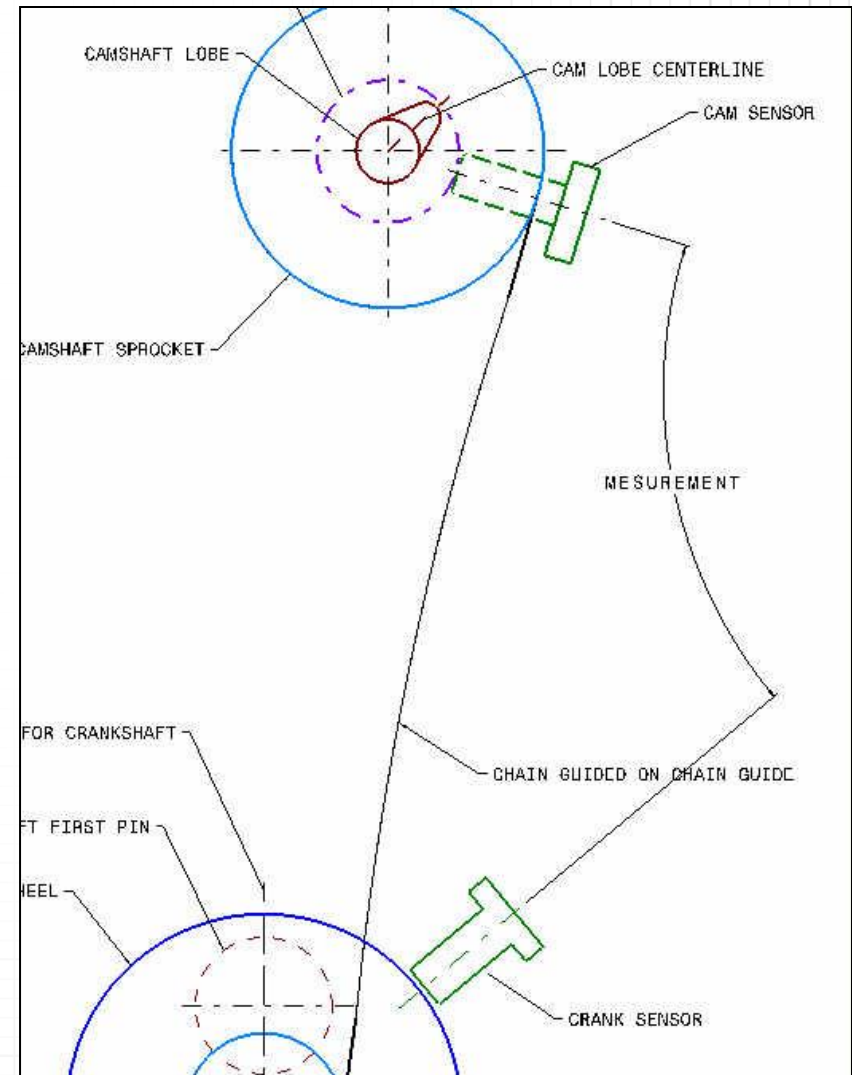

Value Additions

Gives the engineering community an edge over conventional systems

Helps meet government regulations / standard

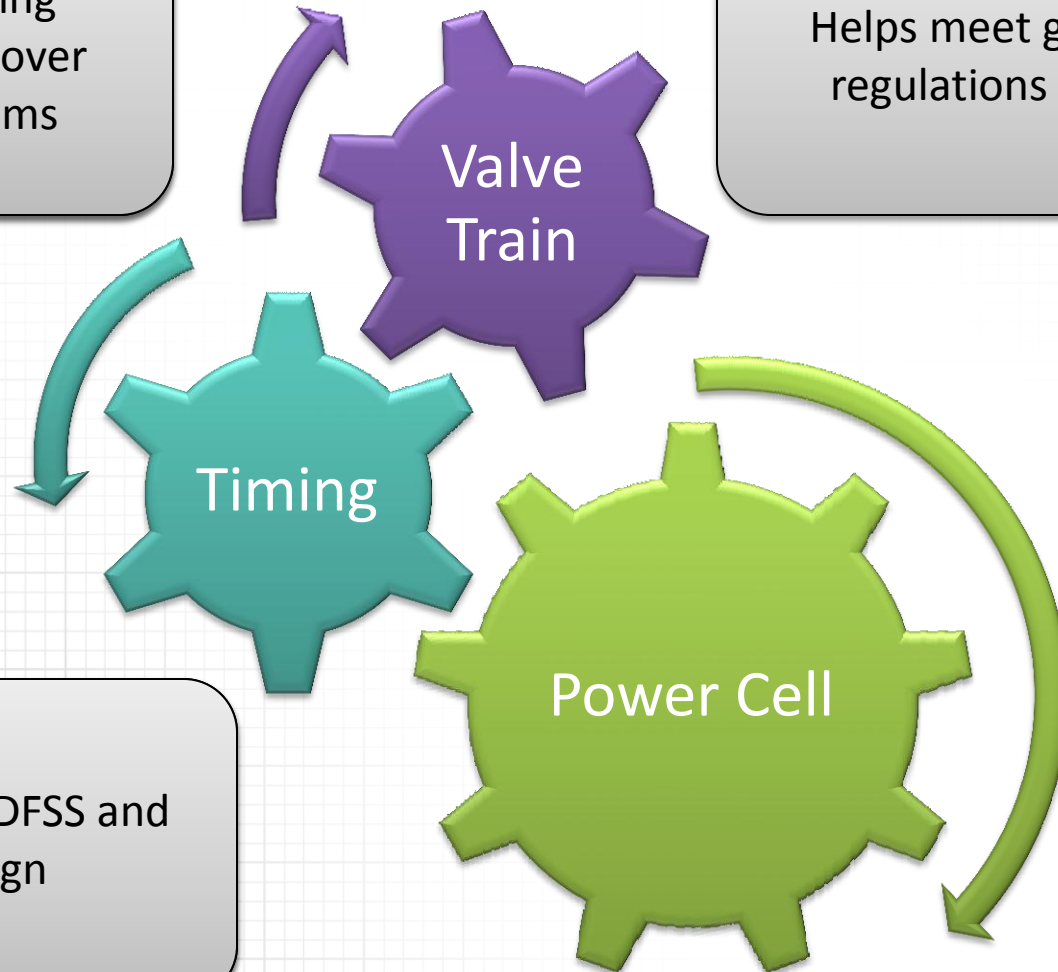

Excellent Tool for DFSS and Robust Design



**THE THINGS WE MAKE
MAKE US**

THANK YOU